



Envirohood

Type 7 Proprietary Kitchen Exhaust Hood





Product Overview

Envirohood type 7 proprietary kitchen exhaust hood removes contaminant air and excess heat generated during the cooking process.

The envirohood are full engineered to maximise effectiveness while minimising energy usage. The envirohood requires 30% - 40% less exhaust air volume than traditional exhaust hoods.

Envirohood are independently certified by **Global-Mark**.
Global-Mark are world recognised independent certifiers.



Stainless steel flame guard honeycomb filter AS 1530.1 CSIRO Certified



www.global-mark.com.au





Features and Benefits

- 1 **Certified exhaust hood design** – Envirohood are independently certified by Global Mark Pty Ltd
- 2 **Lower velocity airflows exhaust hoods** – Larger overhang of the kitchen exhaust hood over the cooking equipment helps capture smoke and heat load inside the hood.
- 3 **CSIRO Certified** – Flameproof stainless steel honeycomb filters which have been independently certified to AS 1530.1 – Methods of fire tests on building materials, components and structures combustibility test materials.
- 4 **Energy savings** – Envirohood utilises 30% - 40% lower exhaust airflow rates due to this factor the kitchen exhaust system will utilise smaller ductwork and kitchen exhaust fan which will result in lower capital costs and energy savings on the equipment usage.
- 5 **Construction** – Fully welded 1.2mm stainless steel 304 Grade No4 finish and polished surfaces.
- 6 **Locally manufactured** – The Envirohood is proudly manufactured in Australia reducing lead times and delivery dates.
- 7 **Air curtain** – Allows containment exhaust air to be trapped inside the proprietary exhaust hood and the air curtain pushes the exhaust air towards the honeycomb stainless steel filters which exhaust air can't escape the exhaust hood into the working area.

Models	Type	Length	Width	Height	Filter Make	Lighting	Construction	Make Up Air / Air Curtain
Envirohood - WM	Wall Mount	Unlimited Length	1400mm	650mm	Stainless Steel honeycomb filter CSIRO certified 1530.1 Tested	LED Downlight IP44 Approved	No 4 finish 304 stainless steel 1.2 mm polished surfaces	Yes
Envirohood - LB	Low - Back	Unlimited Length	1400mm	650mm	Stainless Steel honeycomb filter CSIRO certified 1530.1 Tested	LED Downlight IP44 Approved	No 4 finish 304 stainless steel 1.2 mm polished surfaces	Yes
Envirohood - IH	Island Hood	Unlimited Length	1400mm	650mm	Stainless Steel honeycomb filter CSIRO certified 1530.1 Tested	LED Downlight IP44 Approved	No 4 finish 304 stainless steel 1.2 mm polished surfaces	Yes
Envirohood - DW	Dish-washer	Unlimited Length	1400mm	650mm	Stainless Steel honeycomb filter CSIRO certified 1530.1 Tested	LED Downlight IP44 Approved	No 4 finish 304 stainless steel 1.2 mm polished surfaces	Yes

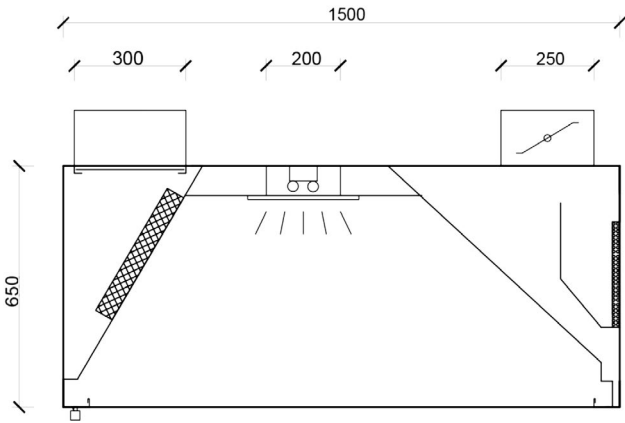

Envirohood - WM (Wall mount)

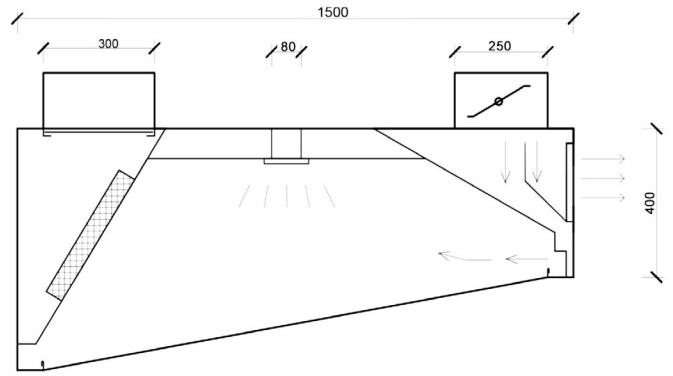

Envirohood - LB (Lowback)

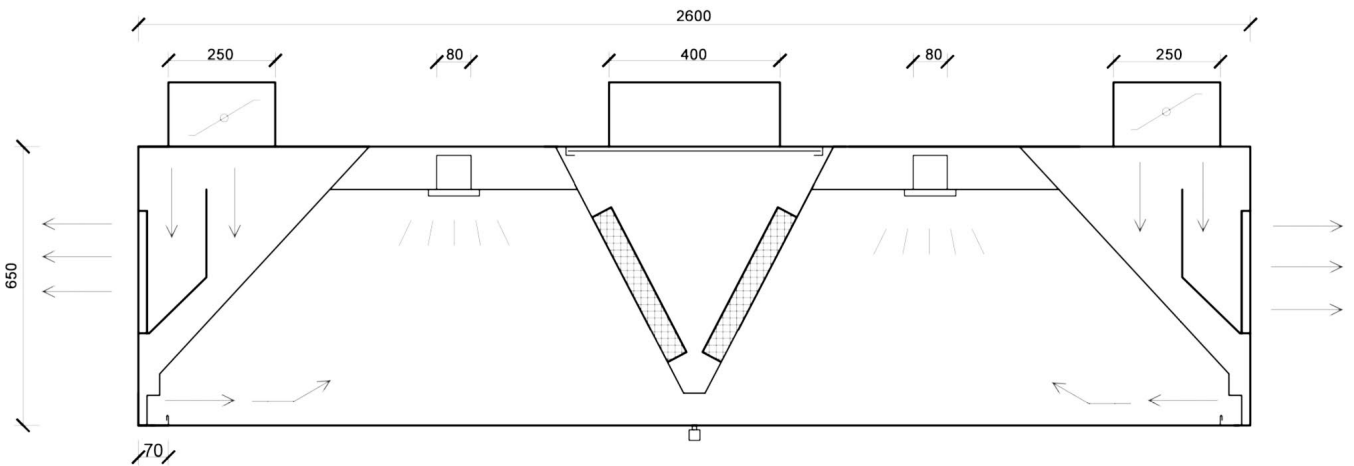

Envirohood - IH (Island Hood)

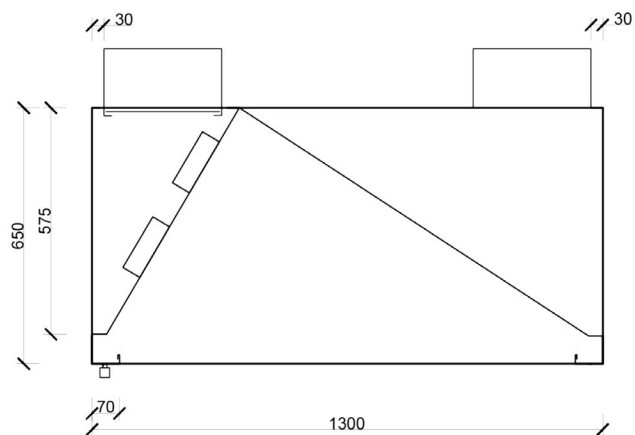

Envirohood - DW (Dish Washer)



Air Odour Solutions Australia
 32 Chifley St, Smithfield NSW 2164
 Tel: 02 9721 0020
 Email: info@aosaus.com.au

www.aosaus.com.au
www.aosnz.co.nz

